

CBCS SCHEME

USN

--	--	--	--	--	--	--	--	--	--

18EE34

Third Semester B.E. Degree Examination, Jan./Feb. 2023 Analog Electronic Circuits

Time: 3 hrs.

Max. Marks: 100

Note: Answer any FIVE full questions, choosing ONE full question from each module.

Module-1

- 1 a. Explain the operation of negative clamper. (06 Marks)
- b. Derive an expression for the stability factor $S_{(V_{BE})}$ and $S_{(I_{CO})}$ for fixed bias circuit. (06 Marks)
- c. Determine the DC bias voltage V_{CE} and the current I_C for the voltage divider bias shown in Fig.Q1(c). Given $\beta = 160$ and assume silicon transistor. (06 Marks)

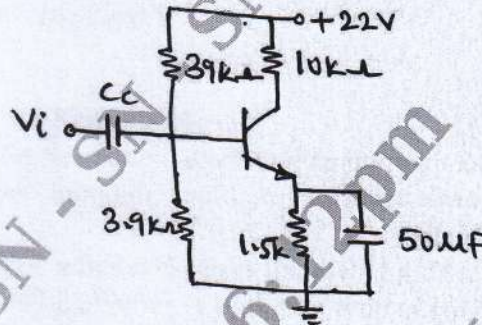

Fig.Q1(c)

(08 Marks)

OR

- 2 a. For the clipper circuit shown in Fig.Q2(a), the input is $50 \sin \omega t$. Draw the transfer characteristics and input-output waveforms, assuming ideal diodes. (10 Marks)

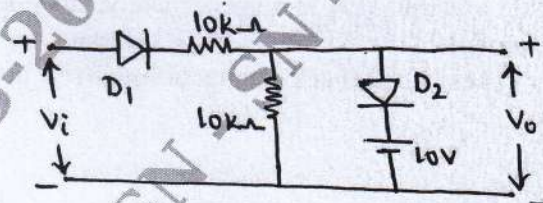

Fig.Q2(a)

(10 Marks)

- b. Design an emitter stabilized circuit using the following data : $I_{CQ} = \frac{1}{2}I_{C(sat)}$, $V_{CE} = \frac{1}{2}V_{CC}$, $V_{CC} = 2V$, $I_{C(sat)} = 10mA$, $\beta = 120$ and $R_C = 4R_E$. (10 Marks)

Module-2

- 3 a. Define h-parameters. Draw the h-parameter model of a transistor in CE mode. (06 Marks)
- b. Derive the expressions for A_i , A_v , R_i and R_o for CE amplifier using complete hybrid equivalent model. (10 Marks)
- c. State and prove Miller's theorem. (04 Marks)

Important Note : 1. On completing your answers, compulsorily draw diagonal cross lines on the remaining blank pages.
2. Any revealing of identification, appeal to evaluator and /or equations written eg, 42+8 = 50, will be treated as malpractice.

OR

- 4 a. Derive an expression for input impedance, output impedance and voltage gain of an emitter follower configuration using approximate hybrid equivalent model. (10 Marks)
- b. For the circuit shown in Fig.Q4(b). Use Miller's theorem calculate A_i , R_i , A_v and R_o . Given $h_{ie} = 1100\Omega$, $h_{fe} = 50$, $h_{oe} = \frac{1}{40} k\Omega$ and $h_{re} = 2.5 \times 10^{-4}$.

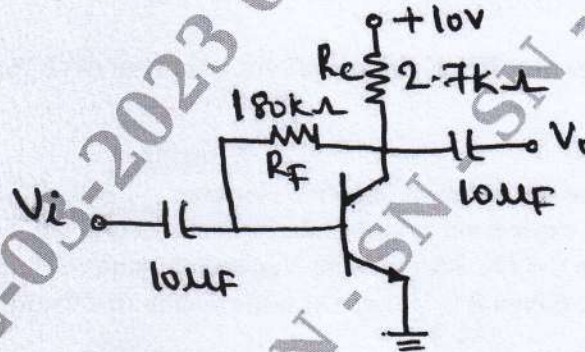

Fig.Q4(b)

(10 Marks)

Module-3

- 5 a. Draw the block diagram of two stage cascade amplifier and explain its advantages. (06 Marks)
- b. Draw a feedback amplifier in block diagram form. Identify each block and explain its function. (08 Marks)
- c. An amplifier with a $1k\Omega$ input resistance and a $50k\Omega$ output resistance, has a voltage gain of 40. The amplifier is now modified to provide a 10% negative voltage feedback in series with the input. Calculate :
- The voltage gain with feedback
 - The input resistance with feedback
 - The output resistance with feedback.

(06 Marks)

OR

- 6 a. Prove that AC voltage gain is approximately unity for a Darlington emitter follower. Use h-parameter model. (10 Marks)
- b. List the four types of feedback connections. Write the block diagram for each and explain. (10 Marks)

Module-4

- 7 a. Discuss the different types of power amplifiers. (05 Marks)
- b. Explain the characteristics of a crystal, with a neat diagram explain the crystal oscillator in parallel resonant circuits. (08 Marks)
- c. A class B amplifier provides a 18V peak signal to a 16Ω load and a power supply of $V_{CC} = 28V$. Determine the input power, output power and circuit efficiency. (07 Marks)

OR

- 8 a. With the help of a circuit diagram, explain the working of transformer – coupled class-B push-pull amplifier. (10 Marks)
- b. Draw and explain the Wein bridge oscillators. Derive the frequency of oscillations. (10 Marks)

(10 Marks)

Module-5

- 9 a. Discuss the difference between JFET and MOSFET. (05 Marks)
 b. Draw the JFET amplifier using fixed bias configuration. Derive i_b , t_o and A_v using small signal model. (10 Marks)
 c. A JFET has $g_m = 5\text{mv}$ at $V_{GS} = -1\text{V}$. Find I_{DSS} if pinch-off voltage $V_p = -2.0\text{V}$ (05 Marks)

OR

- 10 a. Explain the basic operation and characteristics of n-channel depletion type MOSFET. (10 Marks)
 b. For the JFET amplifier shown in Fig.Q10(b). Calculate g_m , r_d , z_i , z_o and A_v . Given $I_{DSS} = 5\text{mA}$, $V_p = -6\text{V}$ and $Y_{Os} = 40\mu\text{s}$.

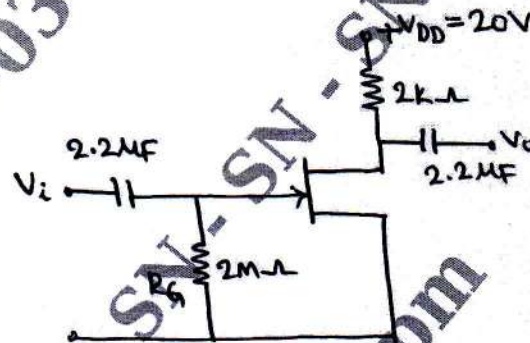

Fig.Q10(b)

(10 Marks)
